

Engineering Specification

Job Name _____

Contractor _____

Job Location _____

Approval _____

Engineer _____

Contractor's P.O. No. _____

Approval _____

Representative _____

LEAD FREE*

Series 957

Reduced Pressure Zone Assembly

2½" – 10"

Series 957 Reduced Pressure Zone assembly provides protection to the potable water system from contamination in accordance with national plumbing codes. The assemblies are normally used in health hazard applications for protection against backsiphonage or backpressure.

The series includes a flood sensor to detect excessive water discharges from the relief valve. The sensor is installed on the assembly exterior and does not alter assembly functions or certifications. The sensor relays a signal that triggers notification to facility personnel for corrective action, thus limiting flooding and costly damage.

NOTICE

An add-on connection kit is required to activate the flood sensor. Without the connection kit, the sensor is a passive component that has no communication with any other device. (For more information download RP/IS-957/957DCDA.)

Features

- Sizes 2½", 3", and 4" available with quarter-turn ball valve shutoffs
- Replaceable check disc rubber
- Extremely compact design
- 70% Lighter than traditional designs
- 304 (Schedule 40) stainless steel housing and sleeve
- Groove fittings allow integral pipeline adjustment
- Patented torsion spring checks provide lowest pressure loss
- Unmatched ease of serviceability
- Bottom mounted cast stainless steel relief valve
- Available with grooved butterfly valve shutoffs
- Sensor on relief valve for flood detection
- Flood alerts feature activated with add-on sensor connection kit, compatible with BMS and cellular network communication

*The wetted surface of this product contacted by consumable water contains less than 0.25% of lead by weight.

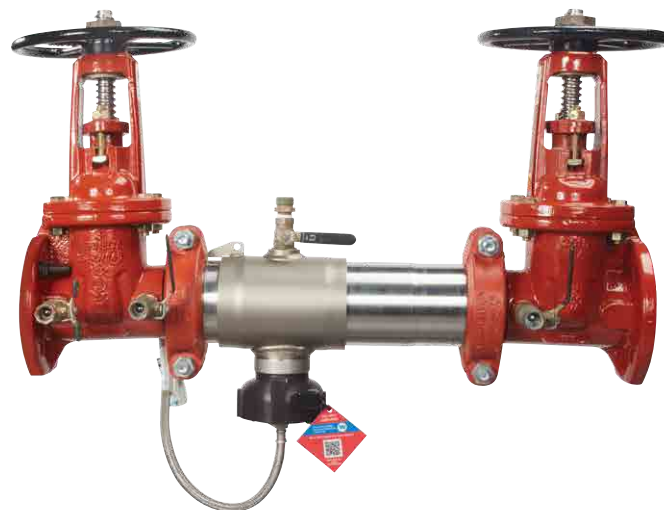

957-OSY with Flood Sensor

NOTICE

Use of the flood sensor does not replace the need to comply with all required instructions, codes, and regulations related to installation, operation, and maintenance of this product, including the need to provide proper drainage in the event of a discharge.

Watts is not responsible for the failure of alerts due to connectivity issues, power outages, or improper installation.

NOTICE

The information contained herein is not intended to replace the full product installation and safety information available or the experience of a trained product installer. You are required to thoroughly read all installation instructions and product safety information before beginning the installation of this product.

Inquire with governing authorities for local installation requirements.

Watts product specifications in U.S. customary units and metric are approximate and are provided for reference only. For precise measurements, please contact Watts Technical Service. Watts reserves the right to change or modify product design, construction, specifications, or materials without prior notice and without incurring any obligation to make such changes and modifications on Watts products previously or subsequently sold.

Specification

The Reduced Pressure Zone assembly shall consist of two independent torsion spring check modules, a differential pressure relief valve located between and below the two modules, two drip tight shutoff valves, and required torsion spring check modules and relief valve shall be contained with a sleeve accessible single housing constructed from 304 (Schedule 40) stainless steel pipe with groove end connections. Torsion spring checks shall have replaceable elastomer discs and in operation produce drip tight closure against the reverse flow of liquid caused by backpressure or backsiphonage. The assembly shall be a Watts Series 957, and shall include a flood sensor on the relief valve for flood detection.

Model/Option

FS	Flood sensor on relief valve for flood detection
NRS	Non-rising stem, resilient seated gate valves
OSY	UL Classified and FM Approved outside stem and yoke resilient seated gate valves
N	N-pattern orientation
Z	Z-pattern orientation
BFG	UL Classified and FM Approved grooved gear operated butterfly valves with tamper switch
QT	2½" - 4" quarter-turn ball valves
OSY FxG**	Flanged inlet gate connection and grooved outlet gate connection
OSY GxF**	Grooved inlet gate connection and flanged outlet gate connection
OSY GxG**	Grooved inlet gate connection and grooved outlet gate connection

Materials

Housing & Sleeve	304 (Schedule 40) stainless steel
Elastomers	EPDM, silicone, and Buna-N
Torsion Spring Checks	Noryl®, stainless steel
Check Discs	Reversible silicone or EPDM
Test Cocks	Lead Free* bronze body
Pins & Fasteners	300 Series stainless steel
Springs	Stainless steel

Pressure — Temperature

Temperature Range	33°F – 140°F (0.5°C – 60°C)
Maximum Working Pressure	175 psi (12.1 bar)

Approvals

- Approved by the Foundation for Cross-Connection Control and Hydraulic Research at The University of Southern California (FCCCHR-USC), excluding 10" N-pattern installation as well as 6" and 10" Z-pattern installations
- AWWA C511-97



For additional approval information, contact the factory or visit watts.com.

NOTICE

When installing a drain line on Series 957 backflow preventers, use 957AG air gaps. Attach the air gap brackets directly onto the flood sensor. For additional information, refer to ES-AG/EL/TC at watts.com

**Options for the gate valve:
– Consult factory for dimensions.
– Available with grooved NRS gate valves; consult factory.
– Post indicator plate and operating nut available; consult factory.

Noryl® is a registered trademark of SHPP Global Technologies B.V.

Dimensions - Weight

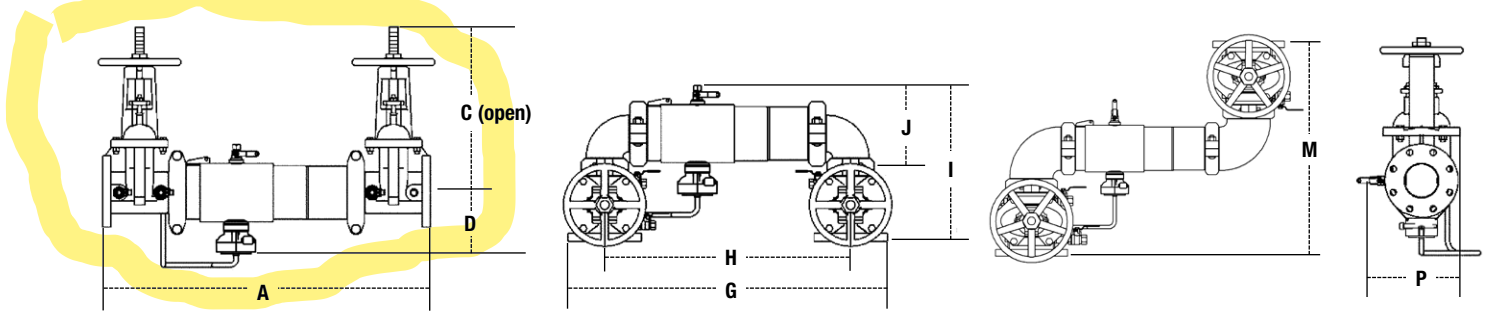

957, 957N, 957Z

SIZE	DIMENSIONS										WEIGHT																	
	A		C (OSY)		C (NRS)		D		G		H		I		J		M		P		957NRS		957OSY		957N NRS		957N OSY	
in.	in.	mm	in.	mm	in.	mm	in.	mm	in.	mm	in.	mm	in.	mm	in.	mm	in.	mm	in.	mm	lb	kg	lb	kg	lb	kg	lb	kg
2½	30¾	781	16¾	416	9¾	238	6½	165	29¼	738	21½	546	15½	393	8¼	223	21¼	540	9¾	234	118	54	128	58	126	57	136	62
3	31¾	806	18¾	479	10¼	260	6½	170	30¼	768	22¼	565	17¼	435	9¾	233	23	584	10½	267	134	61	148	67	147	67	161	73
4	33¾	857	22¼	578	12¾	310	7	178	33	838	23½	597	18½	470	9¾	252	26¼	667	11¾	284	164	74	164	74	187	85	187	85
6	43½	1105	30¾	765	16	406	8½	216	44¾	1137	33½	851	23¾	589	13¼	332	34¼	870	15	381	276	125	298	135	317	144	339	154
8	49¾	1264	37¾	959	19¼	506	9¼	246	54¾	1375	40¾	1019	27¼	697	15¼	399	36¾	937	17¾	437	441	200	483	219	516	234	558	253
10	57¾	1467	45¾	1162	23¼	605	11¾	285	66	1676	49½	1257	32½	826	17¾	440	44½	1124	20	508	723	328	783	355	893	405	950	431

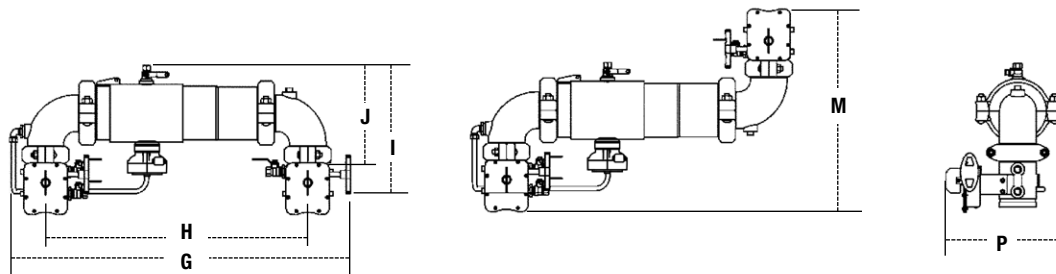

957NBFG, 957ZBFG

SIZE	DIMENSIONS						WEIGHT							
	G		H		I		J		M		P		957N/957Z	
in.	in.	mm	in.	mm	in.	mm	in.	mm	in.	mm	in.	mm	lb	kg
2½	32½	826	23	584	15½	394	9½	241	19¾	502	11¾	300	67	30
3	34	864	24	610	16¾	414	10¼	256	21¼	540	12¾	308	70	32
4	35¾	905	25½	648	17¾	437	10¼	279	23½	597	12¾	321	87	39
6	46½	1181	35¼	895	20½	521	13½	343	27¼	692	15	382	160	73

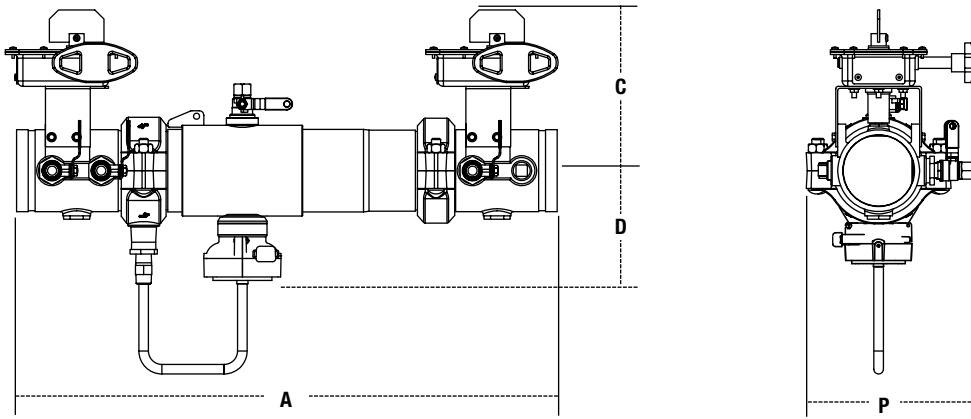

957 BFG

SIZE		DIMENSIONS						WEIGHT		
	A		C		D		P			
<i>in.</i>	<i>in.</i>	<i>mm</i>	<i>in.</i>	<i>mm</i>	<i>in.</i>	<i>mm</i>	<i>in.</i>	<i>mm</i>	<i>lb</i>	<i>kg</i>
4	29	737	7 ³ / ₄	197	6 ³ / ₈	162	9 ¹ / ₂	241	66	30
6	36 ¹ / ₂	927	9 ¹¹ / ₁₆	246	7 ⁷ / ₁₆	189	14 ¹ / ₄	362	122	55

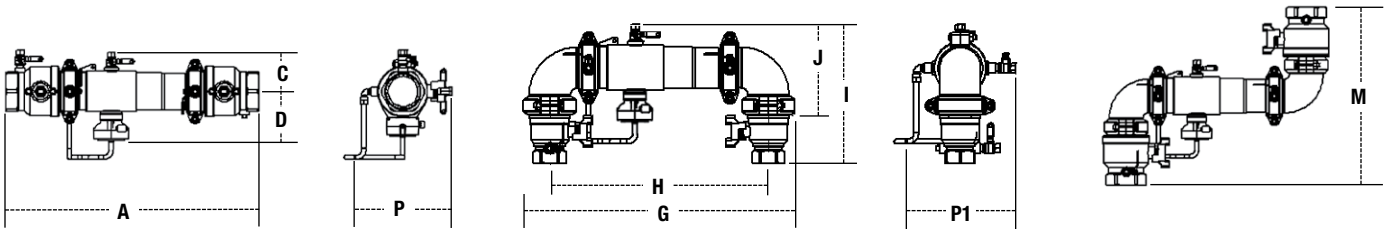

957QT

SIZE		DIMENSIONS											WEIGHT											
	A		C		D		G		H		I		J		M		P		P1		QT		QTN	
<i>in.</i>	<i>in.</i>	<i>mm</i>	<i>in.</i>	<i>mm</i>	<i>in.</i>	<i>mm</i>	<i>in.</i>	<i>mm</i>	<i>in.</i>	<i>mm</i>	<i>in.</i>	<i>mm</i>	<i>in.</i>	<i>mm</i>	<i>in.</i>	<i>mm</i>	<i>in.</i>	<i>mm</i>	<i>in.</i>	<i>mm</i>	<i>lb</i>	<i>kg</i>	<i>lb</i>	<i>kg</i>
2 ¹ / ₂	27 ¹ / ₂	698	4 ⁷ / ₈	124	6 ⁷ / ₈	175	30 ¹ / ₄	768	21 ¹ / ₂	546	16 ¹ / ₁₆	407	11 ³ / ₈	289	19 ⁷ / ₈	505	11 ⁹ / ₁₆	287	11 ⁹ / ₁₆	287	46	21	57	26
3	28	711	4 ⁷ / ₈	124	6 ⁷ / ₈	175	30 ¹ / ₄	768	22 ¹ / ₄	565	16 ⁹ / ₁₆	420	11 ³ / ₈	289	20 ⁷ / ₈	531	11 ⁵ / ₁₆	287	11 ⁵ / ₁₆	287	56	25	67	30
4	28 ³ / ₄	730	4 ⁷ / ₈	124	6 ⁷ / ₈	175	30 ¹ / ₄	768	23 ¹ / ₂	597	18 ⁵ / ₁₆	465	11 ³ / ₈	289	24 ³ / ₈	619	11 ⁵ / ₁₆	287	11 ⁵ / ₁₆	287	76	34	87	39

Capacity

Flow curves as tested by Underwriters Laboratories.

Flow capacity chart identifies valve performance based upon rated water velocity up to 25 fps.

- Service Flow is typically determined by a rated velocity of 7.5 fps based upon schedule 40 pipe.
- Rated Flow identifies maximum continuous duty performance determined by AWWA.

- UL Flow Rate is 150% of Rated Flow and is not recommended for continuous duty.
- AWWA Manual M22 (Appendix C) recommends that the maximum water velocity in services be not more than 10 fps.

Flow characteristics collected using butterfly shutoff valves.

—— Horizontal ——— N-pattern - - - - Z-pattern

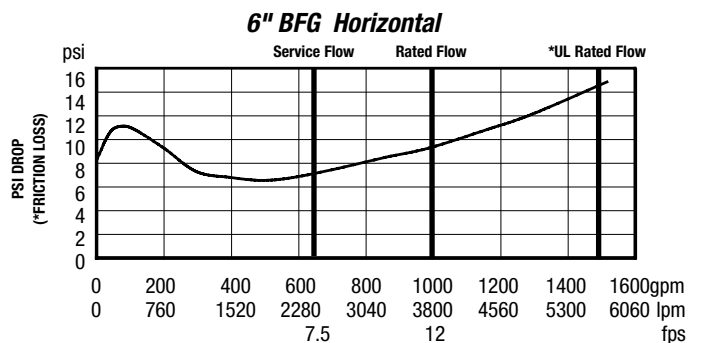
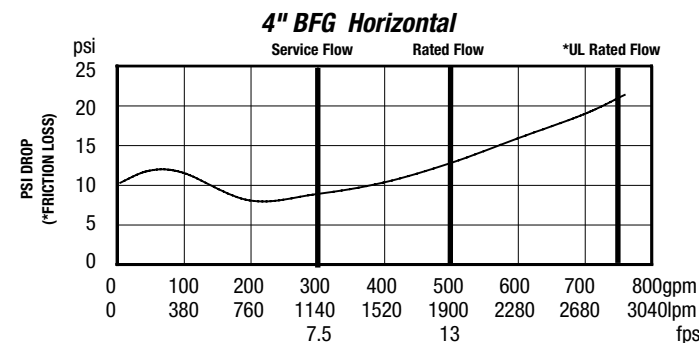
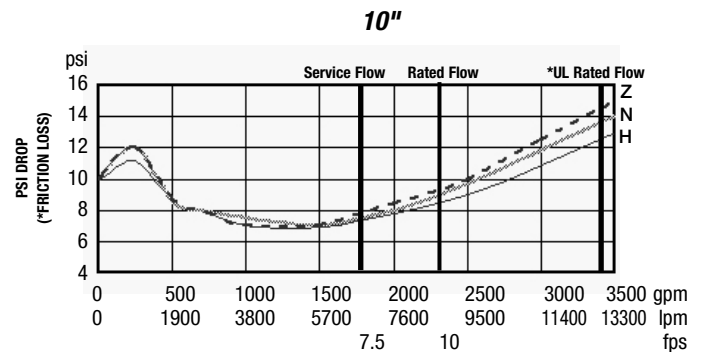
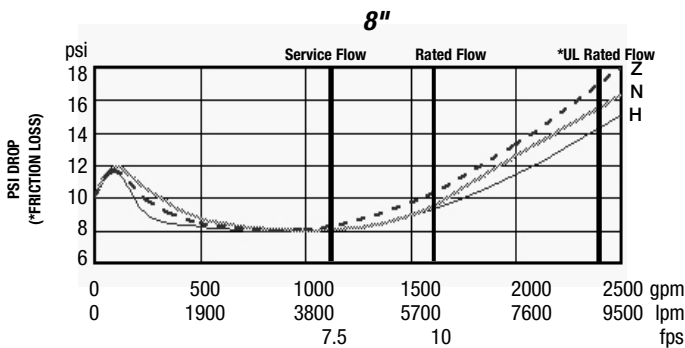
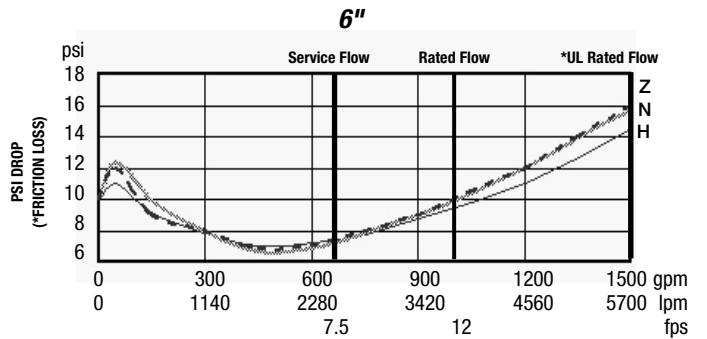
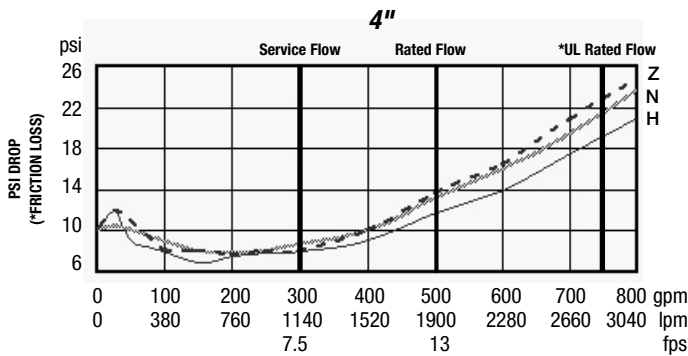
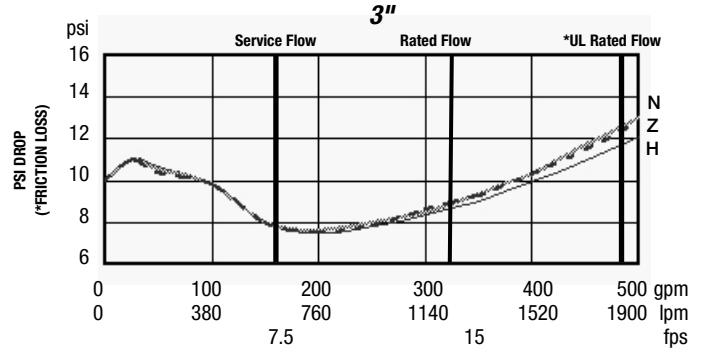
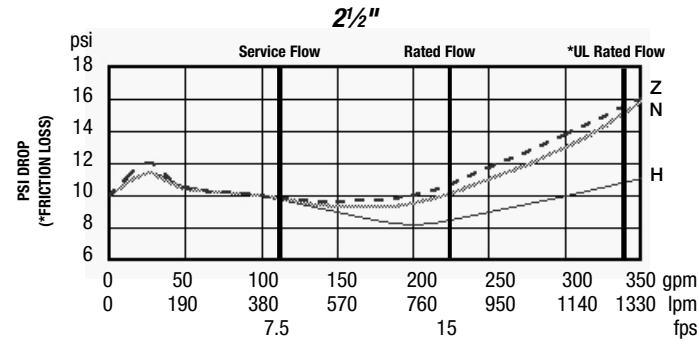

USA: T: (978) 689-6066 • Watts.com
 Canada: T: (888) 208-8927 • Watts.ca
 Latin America: T: (52) 55-4122-0138 • Watts.com